

SPECIFICATIONS & CONSTRUCTION INFORMATION

MODEL: SKDW-525-12 SKID TANK
 DESCRIPTION: ABOVEGROUND, DOUBLE WALL STEEL STORAGE TANK
 INNER TANK: 12 GAUGE
 OUTER TANK: 12 GAUGE
 OPENINGS: MINIMUM 4-2" FNPT COUPLINGS
 1-4" FNPT COUPLINGS
 1-4" FNPT FLANGE
 CONSTRUCTION: WELDED USING UL-142 STANDARDS
 FINISH: SURFACE PREP: SPCC SP-3
 ONE SPRAY COAT OF RED PRIMER
 FINISH ENAMEL COAT IS OPTIONAL

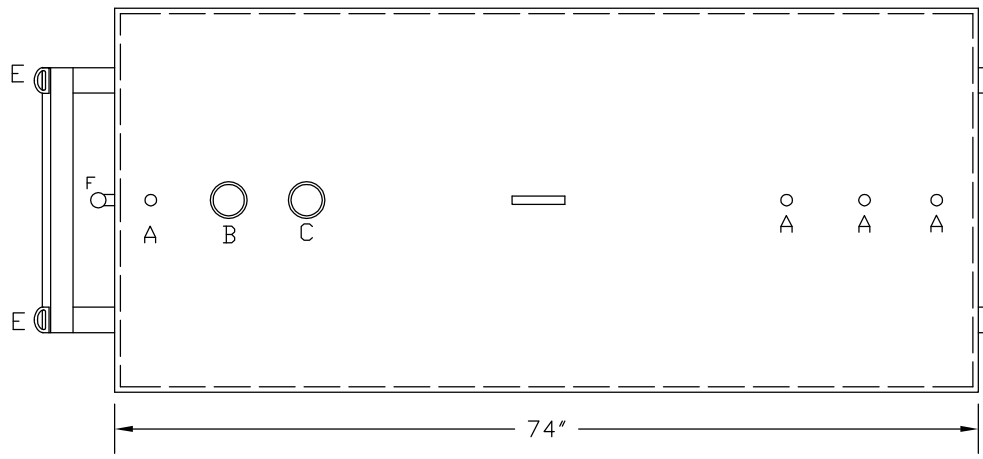
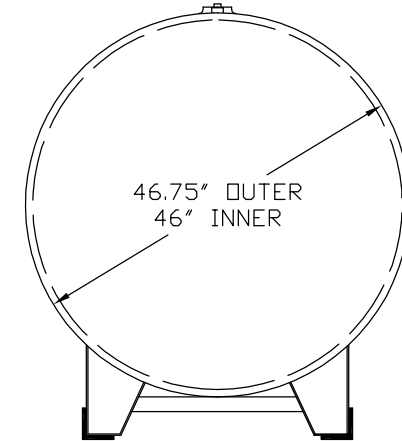
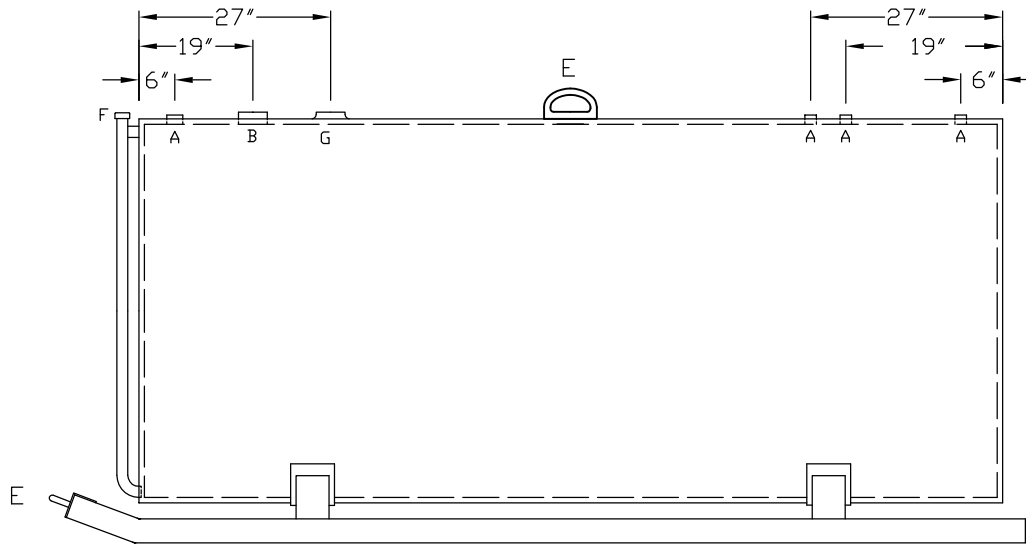

LEGEND

- A - 2" FNPT COUPLING
- B - 4" FNPT COUPLING
- C - 4" FNPT FLANGE
- D - 2" INSPECTION PIPE
- E - LIFT LUG

GOLDSBORO, NC
 1-919-734-8328

TURNER TANKS SKDW-525-12

DWG #: SKDW-525-12	SCALE: NONE	DATE: 12/15/06	REVISION:	APPROVED:	APPROVAL DATE:
--------------------	-------------	----------------	-----------	-----------	----------------