

36" OUTER  
34" INNER

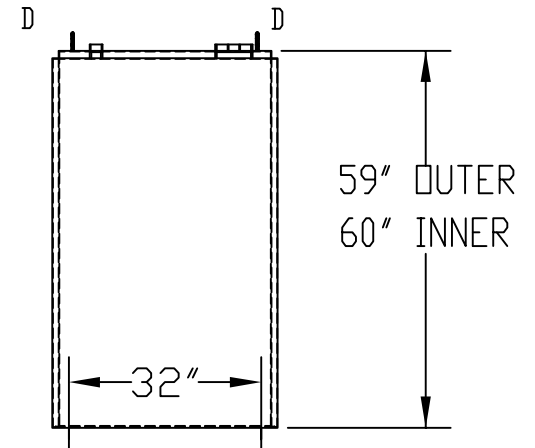
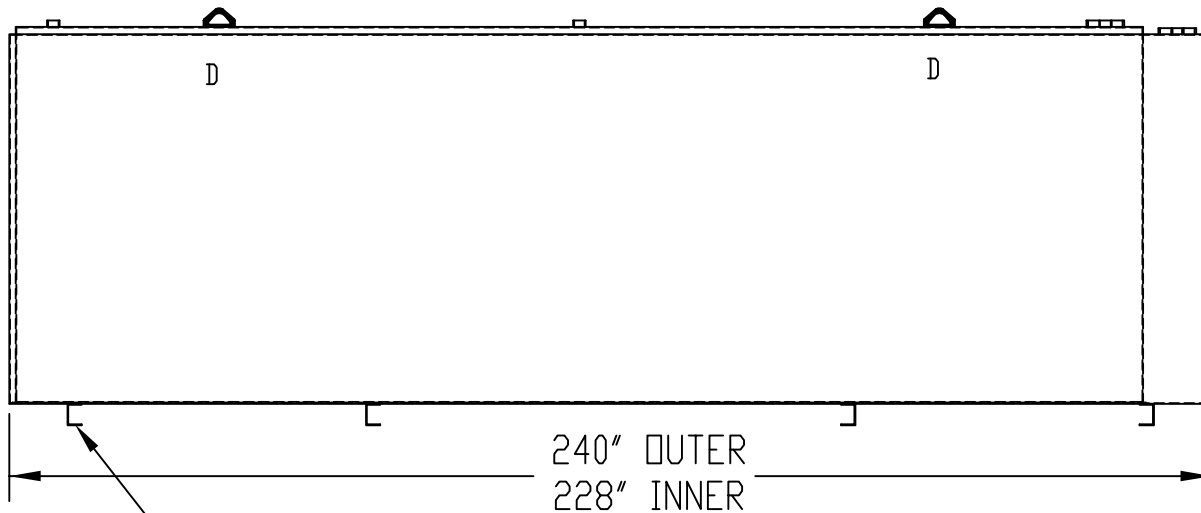

REF. TO: STANDARD TANK  
DATE: 05/28/08

DWG BY: AH

TITLE: **PLTDW-2000-7P**

SCALE: 1:48

DESCRIPTION: ABOVE GROUND, DOUBLE WALL  
7 GA. INNER/10 GA. OUTER  
PIT LUBE, STEEL STORAGE TANK  
CAPACITY: 2,015 GALLONS

FINISH: SURFACE PREP: SPCC SP-3; ONE  
SPRAY COAT OF RED PRIMER  
APPROX. WEIGHT: 2,890 lbs ± 5%



LEGEND: ID - (QTY. OF OPENINGS) PART

A - (5) 2" FNPT FLANGE      C - (1) 6" OUTER E.VENT FLANGE  
B - (1) 6" INNER E.VENT CPL      D - (2) FORGED LIFT LUG



1500 HWY 117 S.  
GOLDSBORO, NC 27530  
P: (919) 734-8328  
F: (919) 736-4550

SIGNED APPROVAL: