

SPECIFICATIONS & CONSTRUCTION INFORMATION

MODEL: AUDW-525-12B
 DESCRIPTION: ABOVEGROUND, DOUBLE WALL STEEL STORAGE TANK
 CONSTRUCTION: WELDED USING UL-142 STANDARDS
 FINISH: SURFACE PREP: SPCC SP-3
 ONE SPRAY COAT OF RED PRIMER
 FINISH ENAMEL COAT IS OPTIONAL

INNER TANK: 12 GAUGE
 OUTER TANK: 12 GAUGE
 OPENINGS: MINIMUM 3-2" FNPT COUPLINGS
 1-4" FNPT COUPLING
 1-4" FNPT FLANGE

GOLDSBORO, NC
 1-919-734-8328

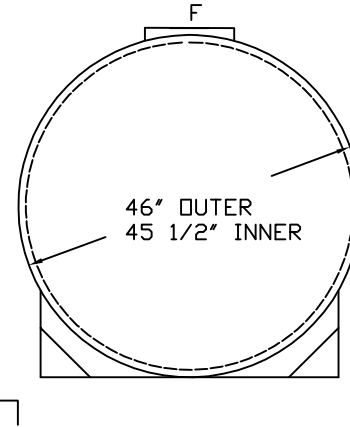
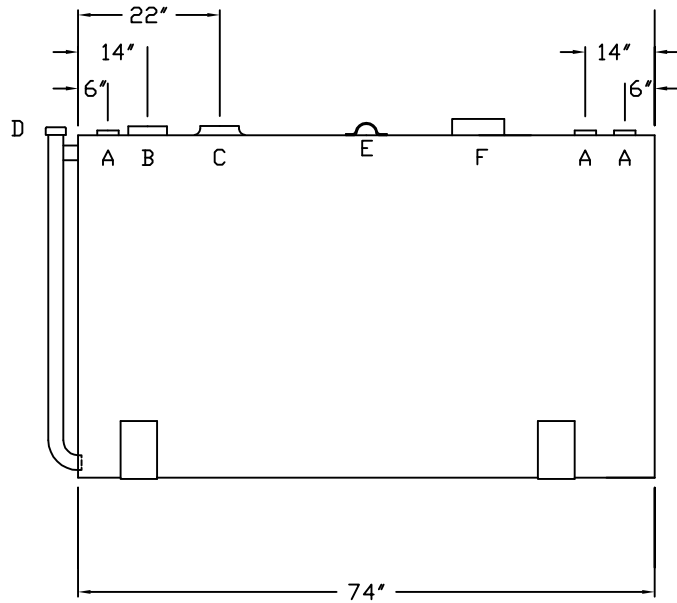

FINISH COLOR CASTROL GREEN

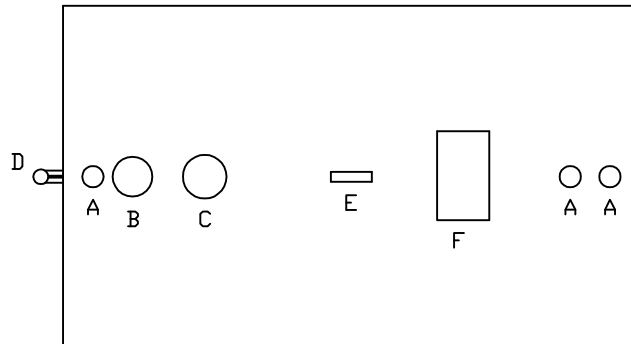

LEGEND

- A - OPENINGS FOR FILL, GAUGE, AND NORMAL VENT: 2" FNPT COUPLING
- B - OPENING FOR INNER TANK EMER. VENT 4" COUPLING
- C - OPENING FOR OUTER TANK EMER. VENT 4" FLANGE
- D - INTERSTICE INSPECTION TUBE
- E - LIFT LUG
- F - TURNER REEL MOUNTING PLATE

TURNER TANKS AUDW-525-12B