

*Typical 1/8" thick pad,
fully sealed weld between tank and
saddle.

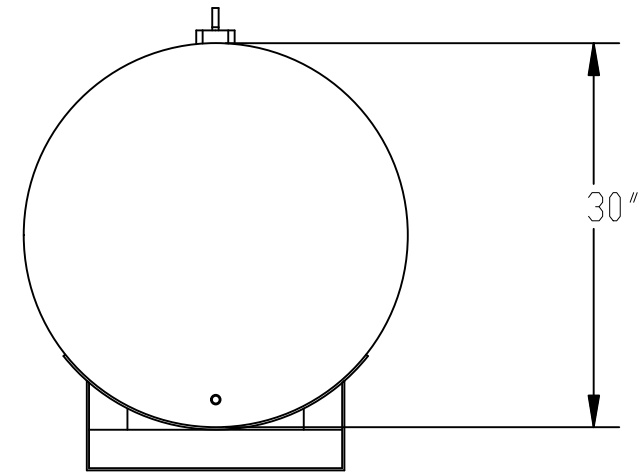
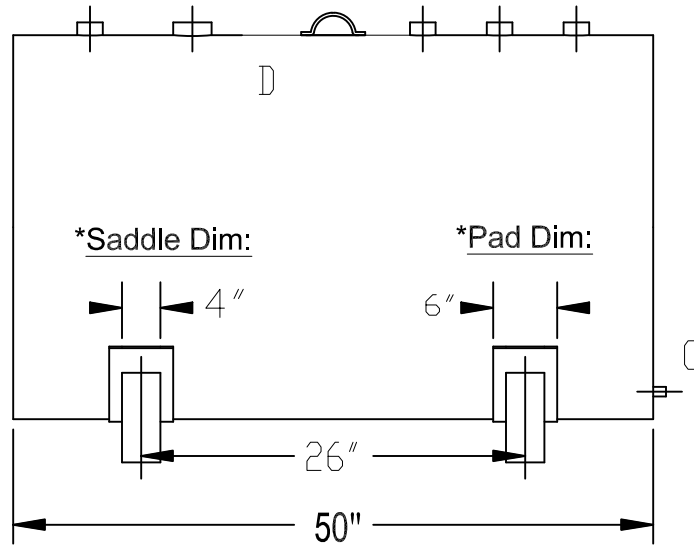
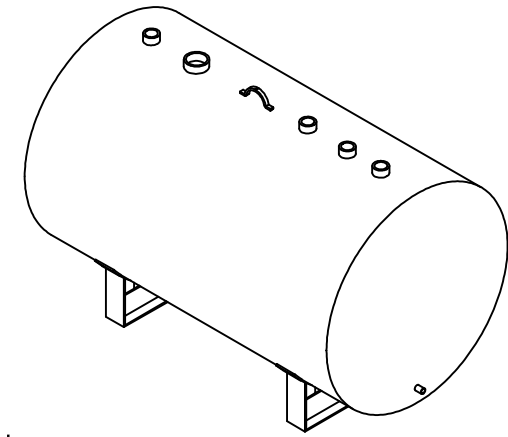

TITLE: **AS-150-12P**

DESCRIPTION: ABOVE GROUND, SINGLE WALL
12 GA. STEEL STORAGE TANK

FINISH:
SURFACE PREP: SPCC SP-3; ONE
SPRAY COAT OF PRIMER; OPT FINISH
APPROX. WEIGHT: 235 lbs ± 5%

LEGEND: ID - (QTY. OF OPENINGS) PART

A - (4) 2" FNPT FLANGE C - (1) 3/4" FNPT FLANGE
B - (1) 3" E.VENT FLANGE D - (1) LIFTING LUG

CAPACITY: 147 GALLONS



1500 HWY 117 S.
GOLDSBORO, NC 27530
(919) 734 - 8328
1-800-661-3767



Underwriters
Laboratories Inc.
LISTED ®